

# MODEL RANGE

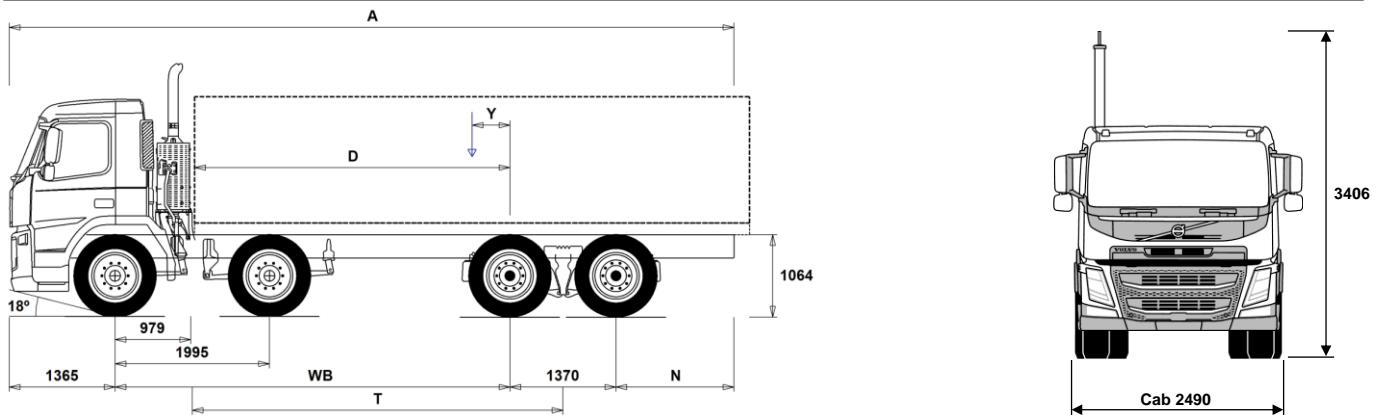

Volvo Trucks. Driving Progress

FM 11 8x4 Platform - Rear Air Suspension - N3 Cranked front axles for on road work FM



## Chassis Dimensions [mm]

WB Wheelbase	5100	5600	6000	6400
A Overall Chassis Length	10660	11410	12060	11610
D Center of rear axle to front of body	4071	4571	4971	5371
N Rear Overhang (Min)	1225	1225	1225	1225
N Rear Overhang (Max)	2825	3075	3325	2475
T Theoretical Wheelbase	4788	5288	5688	6088
Y Center of Gravity for Payload (Min)	688	846	973	1085
Y Center of Gravity for Payload (Max)	1327	1554	1736	1902

## Chassis Weights [kg]

Front Axles	6555	6505	6485	6500
Rear Bogie	2970	3070	3160	3145
Kerb Weight	9525	9575	9645	9645
Payload (including body, driver, fuel etc)	22475	22425	22355	22355

## Turning Diameter [mm]

Turning Circle Diameter Kerb to Kerb	20600	22200	23500	24800
Turning Circle Diameter Wall to Wall	22000	23700	24900	26200

## Plated Weights [kg]

	Plated	Design
Gross Vehicle Weight	32000	37000
Gross Combination Weight	44000	44000
Front Axles	16000	16000
Rear Bogie	19000	21000

## Important Notes

### Chassis Dimensions

Cab Height: +167 mm for CAB-HSLP, -499 mm for CAB-LSLP, +167 mm for CAB-SLP, +224 mm for CAB-XHSL.

Front Axle to Back of Cab: +506 mm for CAB-HSLP and CAB-SLP and CAB-XHSL, -39 mm for CAB-LSLP.

D-measure includes a front clearance of 50 mm and for rigid trucks also a subframe of 100 mm.

Height can vary  $\pm 20$  mm for leaf and  $\pm 10$  mm for air suspension.

All dimensions are for unladen chassis and any tag axles down.

Rear overhang used for vehicle weight calculation is the maximum rear overhang (N Max) for selected wheelbase.

Weight and dimensions are based upon the following tyres:

Front Axle Tyres:	315/80R22.5
Drive Axle Tyres:	315/80R22.5

**Chassis weight includes oil, water, AdBlue, 70 litres fuel and without driver. Kerb weight can vary  $\pm 3\%$ .**

Turning diameters are theoretically calculated.

Legal weights can differ from country to country.

For more detailed weight information, including optional equipment weights, ask your Volvo sales contact to enter your specification into the Volvo Weight Information system (WIS).

Do NOT use this drawing for bodybuilding. Refer to Volvo Bodybuilder Instructions and chassis assembly drawing FM84FR1HA.

# MODEL RANGE

## FM 11 8x4 Platform - Rear Air Suspension - N3 Cranked front axles for on road work FM

### TRUCK USE

- **RC-ROUGH** Operating class on/off road
- **RC-SMOOTH** Operating class highway
- **RC-VROUGH** Very rough road conditions
- **TIPP-PRE** Tipper vehicle preparation
- **UNIFORM** Basic platform vehicle

### CORE COMPONENTS

- **CHH-HIGH** Chassis frame height standard 1020 -1150mm nominal above ground level - subject to tyre size  
For specific coupling or deck heights always check the unique BEP chassis drawing
- **CHH-MED** Chassis frame height medium - approx 900 to 1000mm nominal above ground level - subject to tyre size  
For specific coupling heights always check the unique BEP chassis drawing
- **RADD-GR** Rear air suspension, 2 axles - 2 driven
- **FM-DAY** Day cab - with steel safety cage design  
Designed and built to Swedish impact and ECE R29 regulations
- **FM-HSLP** Globetrotter cab - with steel safety cage design  
Designed and built to Swedish impact and ECE R29 regulations
- **FM-LSLP** Low sleeper cab - with steel safety cage design  
Designed and built to Swedish impact and ECE R29 regulations
- **FM-SLP** Sleeper cab - with steel safety cage design  
Designed and built to Swedish impact and ECE R29 regulations
- **FM-XHSL** Globetrotter LXL cab - with steel safety cage design  
Designed and built to Swedish impact and ECE R29 regulations
- **EU6SCR** Emission level - Euro 6
- **D11K330** D11K330 10.8l engine developing 330hp at 16-1900rpm.  
Peak torque 1600Nm at 950-1400rpm.
- **D11K370** D11K370 10.8l engine developing 370hp at 16-1900rpm.  
Peak torque 1750Nm at 950-1400rpm.
- **D11K410** D11K410 10.8l engine developing 410hp at 16-1900rpm.  
Peak torque 1950Nm at 1000-1400rpm.
- **D11K450** D11K450 10.8l engine developing 450hp at 16-1900rpm.  
Peak torque 2150Nm at 1000-1400rpm.
- **EBR-EPG** Exhaust brake controlled by steering column switch
- **EBR-EPGC** Exhaust pressure governor for I shift gearbox
- **EBR-VEB** Volvo engine brake and exhaust pressure governor retardation 300kW
- **AT2412E** AT2412E 12-speed "I-shift" automated mechanical gearbox suitable for gross train weights up to 44tonne only refer to sales engineering when used in conjunction with a PTO
- **AT2612E** AT2612E 12-speed "I-shift" automated mechanical gearbox suitable for gross train weights up to 60tonne only refer to sales engineering when used in conjunction with a PTO
- **ATO2612E** ATO2612E 12-speed "I-shift" overdrive automated mechanical gearbox suitable for gross train weights up to 60tonne refer to sales engineering when used in conjunction with a PTO
- **PT2106** Powertronic automatic 6-speed gearbox, max. engine torque 2100 Nm, max. permitted GCW 100000 kg
- **VT2009B** VT2009B - 9 speed range change gearbox
- **VT2214B** VT2214B Manual 14-speed range & splitter gearbox
- **VT2514B** VT2514B Manual 14-speed range & splitter gearbox
- **VTO2214B** VTO2214B Manual 14-speed range & splitter gearbox with overdrive top gear
- **VTO2514B** VTO2514B Manual 14-speed range & splitter gearbox with overdrive top gear
- **RTH2610F** Rear tandem axle, hub reduction, 26 tonnes, GCW 100 tonnes
- **RTS2370A** RTS2370A single reduction tandem 23tonne drive axles with differential and cross locks. - design GCW 70tonnes

■ Standard Equipment

□ Optional Equipment

For more detailed information about cab and powertrain equipment, please refer to separate specification sheets.

For all possible options and combinations of options please consult your Volvo sales contact who can create a specification to match your requirements using the Volvo Sales Support system (VSS).

The factory reserves the right to modify design and change equipment without previous notification. The specification can vary from country to country.

### PACKAGES

- **LHFP-V** Long Haul Fuel Economy driving package
- **DRIVEFM** Driving package
- **DRIVEFM+** Driving plus package
- **1BEDFM** One bed resting package
- **2BEDFM** Two bed resting package
- **AUDBAS** Audio basic: RDS radio with CD player, FM/AM antenna and speakers in dashboard and doors.
- **AUDHIG** High Power Audio system: RDS radio with CD player - also playing MP3/WMA files from CD -, with integrated bluetooth phone and USB/Line inputs. FM/AM antenna, speakers in dashboard, doors, and sleeping compartment.
- **VISI15** Visibility package
- **VISI15+** Visibility plus package

### CHASSIS

- **FST-AIR** Front suspension type - air
- **FST-PAR** Front suspension type - 2 leaf parabolic springs
- **FST-PAR3** Front suspension type - 3 leaf parabolic springs
- **FAL16.0** Front axles design capacity 16 tonnes - 2 x 8.0 tonne front axles
- **FAL18.0** Front axles design capacity 18 tonnes - 2 x 9 tonne front axles
- **FSM-LUB** Lubricated rear shackles on front suspension pins and bushings
- **FSTAB** Front anti-roll bar
- **FSTAB2** Front anti-roll bar medium stiffness
- **RAL21** Rear bogie design capacity 21 tonnes
- **RAL23** Rear bogie design capacity 23 tonnes
- **RAL26** Rear bogie design capacity 26 tonnes
- **RAL32** Rear bogie design capacity 32 tonnes
- **RSTAB1** Rear anti-roll bar
- **RSTAB3** Rear stiff anti-roll bar
- **RALIM105** Rear axle load limiter, 10.5 tonnes
- **RALIM115** Rear axle load limiter, 11.5 tonnes
- **RALIM13** Rear axle load limiter, 13 tonnes
- **RALIM15** Rear axle load limiter, 15 tonnes
- **RALIM95** Rear axle load limiter, 9.5 tonnes
- **ACTST-TO** Volvo Dynamic Steering (VDS) with with extra electronic pump and torque overlay
- **PSS-DUAL** Dual power steering system
- **PSP-VAR** Power steering pump with variable displacement
- **EBS-MED** EBS medium package including "hill" hold function
- **AUXPARK** Additional spring parking brakes
- **ABS** Anti lock brakes
- **FBREG-E** Front regulating brake valve, EBS
- **FBREG-LS** Front regulating brake valve, load sensing
- **SUSPL-EC** Remote electronic control on wander-lead for air suspension levelling
- **FRAME300** Frame rail section external height 300 mm
- **FST8080** Frame thickness - web and flange 8.0mm
- **FIL-EEEE** Inner liner from end of engine to end of bogie
- **FIL-EEEF** Inner liner from end of engine to end of frame
- **FIL-FBEB** Inner liner over rear bogie
- **FIL-FBEF** Inner liner from front of bogie to end of frame
- **FIL-TXEB** Inner liner from gearbox member to end of bogie
- **FIL-TXEF** Inner liner from gearbox member to end of frame
- **BBOX-L** Battery box located on left hand side
- **2BATT170** 2 x 170 Ah capacity batteries
- **2BATT225** 2 x 225 Ah capacity batteries
- **BATTAMP** Battery voltage and ampere gauge
- **BATTIND** Battery charge indication

# MODEL RANGE

## FM 11 8x4 Platform - Rear Air Suspension - N3 Cranked front axles for on road work FM

- ADR1** ADR package for transportation of dangerous goods on road (Note does NOT include safe loading pass package if required this is quoted separately)
- ADR2** ADR package for transportation of dangerous goods on road (Note does NOT include safe loading pass package if required this is quoted separately)
- MSWI-A** Main switch - ADR switch circuit shut down
- MSWI-C** Main switch - Chassis mounted toggle switch by battery box
- MSWI-R** Main switch - Key fob operated remote controlled
- R315A56** Right aluminium 560 mm D-shaped fuel tank, 315 litres volume  
Min volume 255l  
Max volume 810l
- UL-FUEL** Without left fuel tank
- ADTP-L** AdBlue tank on left hand side
- ADTP-LF** AdBlue tank on left hand side at the front
- ADB032** AdBlue tank usable volume 32 litres
- ADB048** AdBlue tank usable volume 48 litres
- ADB064** AdBlue tank usable volume 64 litres
- ADTC-BF** AdBlue tank cover with satin alloy look decorative cover
- FCAP-L** Locking fuel filler cap
- FUFF-AS** Fuel filling anti-spillage device
- FUFF-ATS** Fuel filling anti-theft and anti-spillage devices
- ESH-LEFT** Horizontal silencer, left exhaust outlet
- ESH-REAR** Horizontal silencer, rear exhaust outlet
- ESH-RIGH** Horizontal silencer, right exhaust outlet
- ESH-VERT** Horizontal silencer, vertical exhaust outlet
- ESHVERT** Horizontal chassis mounted diesel particulate filter and vertical SCR silencer behind cab
- EXST-SSP** Stainless steel exhaust stack
- EXST-ST** Steel exhaust stack
- WHC-FIX2** Two fixed wheel chocks
- WHC-FOL2** Two foldable wheel chocks
- WHCP-F** Wheel chock(s) stored in the front part of the vehicle
- WHCP-R** Wheel chock(s) stored in the rear part of the vehicle
- TB-L80** Toolbox 800 mm, left side
- TB-R80** Toolbox 800 mm, right side
- SUP-BAS** EC approved chassis side guards
- SUP-LOW** EC approved low chassis side guards
- CHAIN-S** Snow chains
- HOOK-SC** Snow chain hooks
- TOWF-NO1** One front towing device
- TOWF-NO2** Two front towing devices
- TOWMBRH** Towing member, high mounted in centre of frame, D = 190
- TOWMBRL1** Towing member, low mounted under the frame
- TOWMBRM** Towing member, medium mounted in line with frame lower flange
- RFEC-S** Rear frame end, straight cut for regular platform applications
- RFEC-U** Rear frame end, upper cut for tipper applications.
- C-RI4040** Towing coupling, Ringfeder 4040 G-150
- C-RI5055** Towing coupling, Ringfeder 5055 G-150
- C-RO400G** Towing coupling, Rockinger 400 G-150 for 40mm eyes
- C-RO50** Rockinger RO 50 50mm for centre axle trailer
- TOWR-ONE** Towing hitch attached to rear crossmember
- TREL-PK** Trailer electrical preparation kit - chassis/cab wiring
- TREL14** Single 14 pole electrical trailer connector
- TREL15** Single 15 pole electrical trailer connector - ADR certified
- TREL7** 7 pole - 24N trailer electrical suzie
- TREL7-7** 24N and 24S trailer electrical suzies
- TBC-DUO** Duomatic type air line connectors
- TBC-EC** Palm coupling type air line connectors
- TRBR-HCF** Full pressure hand controlled trailer brake
- TRBR-STA** Stationary trailer brake control
- TRB-STRE** Stretch Brake - Automatic low speed trailer brake activation to avoid jack-knifing and improve steerability
- RUP-FOSL** Folding & sliding EC approved aluminium rear underrun
- FFEND-B** Standard mounted mud wings on second front axle
- FFEND-T** Transport mounted mud wings on second front axle
- RFEND-B** Three piece EC approved rear mud wings and spray flaps
- RFEND-T** Rear mud wings, transport mounted
- RFH-BAS** Basic rear wing height
- RFH-HIG** High rear wing height - higher wing tops
- RFH-LOW** Lower rear wing height - shallower wing tops
- ATANK-AL** Aluminium air tanks
- ATANK-ST** Steel air tanks
- TL-LED** LED Tail lights
- BLIGHT-E** Emergency brake light

### WHEELS & TYRES

- RT-AL** Alcoa brushed aluminium rims with standard holes for long stud fixing on all axles
- RT-ALDP** Alcoa Dura-Bright EVO aluminium rims with standard holes long stud fixing on all axles, requires cleaning with a ph neutral solution - washing up liquid.
- RT-ALDPD** Alcoa Dura-Bright EVO aluminium rims with countersunk holes for short stud fixing on all axles, requires cleaning with a ph neutral solution - washing up liquid.
- RT-ALDU** Alcoa brushed aluminium rims with countersunk holes for short stud fixing on all axles
- RT-SPOKE** Spoke rims on all axles
- RT-STEEL** Steel rims on all axles
- WCAP** Aerodynamic hub caps
- SPWT-D** Spare wheel & tyre with rear tyre pattern
- SPWT-F** Spare wheel & tyre with front tyre pattern
- SWCP-LF** Spare wheel carrier on left side of chassis ahead of rear axle
- SWCP-T** Spare wheel supplied temporarily strapped to chassis
- SWCP-TP** Temporary spare wheel carrier on top of chassis frame
- JACK-12T** 12 tonne bottle jack
- JACK-15T** 15 tonne bottle jack
- JACK-20T** 20 tonne bottle jack
- TOOL-BAS** Basic Toolkit
- TOOLKIT** Complete tool kit
- INFLAHOS** Tyre inflation hose
- GAUGE-TP** Tyre pressure gauge

### DRIVELINE EQUIPMENT

- TRAP-HD** Reinforced gearbox application
- TP-DICON** I-shift software - Distribution and Construction
- TP-FUEC** I-shift software - Long Haul, Fuel & economy
- TP-FUEC3** I-shift software - I SEE Long Haul Fuel & Economy Works with cruise control, inclinometer and GPS to learn the route travelled and or used centrally stored data for maximum economy
- TP-HD** I-shift software - Heavy duty for high GCW  
Special conditions apply consult Sales Engineering
- AMSO-AUT** Enhanced I-shift software with manual shift available in auto mode and kickdown facility on accelerator pedal
- AVO-ENH** Enhanced software for off road driveability and starting
- APF-ENH** I-shift enhanced PTO functions
- CD40B-O** Twin plate 394mm (16") clutch
- CS43B-O** Single plate 430mm (17") clutch
- RET-TH** Gearbox mounted retarder
- RET-TPT** Hydraulic Retarder for Powertronic gearbox

Standard Equipment       Optional Equipment

For more detailed information about cab and powertrain equipment, please refer to separate specification sheets.

For all possible options and combinations of options please consult your Volvo sales contact who can create a specification to match your requirements using the Volvo Sales Support system (VSS).

The factory reserves the right to modify design and change equipment without previous notification. The specification can vary from country to country.

# MODEL RANGE

## FM 11 8x4 Platform - Rear Air Suspension - N3 Cranked front axles for on road work FM

<input type="checkbox"/> <b>TC-HWO</b>	Automatic gearbox oil cooler - water to oil	<input type="checkbox"/> <b>HPG-F61</b>	flow, hydraulic pump
<input type="checkbox"/> <b>TC-MAOH2</b>	Extra high performance transmission oil cooler - air to oil with front mounted radiator	<input type="checkbox"/> <b>HPG-F81</b>	Parker F1-61 gearbox mounted, fixed displacement, single flow, hydraulic pump
<input type="checkbox"/> <b>TC-MWO</b>	Basic transmission oil cooler - water to oil	<input type="checkbox"/> <b>HPG-V120</b>	Parker F1-81 gearbox mounted, fixed displacement, single flow, hydraulic pump
<input type="checkbox"/> <b>TC-MWOH2</b>	High performance transmission oil cooler - water to oil		Parker VP1-120 variable displacement, single flow, gearbox mounted hydraulic pump
<input type="checkbox"/> <b>TC-RAO</b>	Transmission oil cooler for retarder - air to oil	<input type="checkbox"/> <b>EIDLESD</b>	Engine idle shut down
<input type="checkbox"/> <b>TC-RWO</b>	Transmission oil cooler for retarder - water to oil	<input type="checkbox"/> <b>STWPOS-L</b>	Left hand drive
<input type="checkbox"/> <b>2COM1100</b>	Two cylinder, air compressor, 1100 litres per minute	<input checked="" type="checkbox"/> <b>STWPOS-R</b>	Right hand drive
<input checked="" type="checkbox"/> <b>2COMP900</b>	Two cylinder, air compressor, 900 litres per minute	<input type="checkbox"/> <b>STWM-LE</b>	Leather steering wheel
<input type="checkbox"/> <b>CLU-AIRC</b>	Clutchable air compressor	<input checked="" type="checkbox"/> <b>STGW-ADJ</b>	Adjustable steering wheel
<input checked="" type="checkbox"/> <b>AIRIN-HI</b>	Roof mounted air intake behind cab on left hand side	<input checked="" type="checkbox"/> <b>AIRBAG</b>	SRS Driver's air bag
<input type="checkbox"/> <b>AIRIN-LO</b>	Low level air intake behind cab on left hand side	<input checked="" type="checkbox"/> <b>1DAYDIG</b>	Continental VDO DTCO 2.0 digital tachograph This tachograph can ONLY offer remote download if the option of Dynafleet or an FMS gateway has been specified with this order.
<input type="checkbox"/> <b>ACL1ST-S</b>	Two stage air filter	<input type="checkbox"/> <b>ARSL</b>	Additional road speed limit - switch in dashboard
<input checked="" type="checkbox"/> <b>24AL110B</b>	110 amp alternator	<input type="checkbox"/> <b>CRUISE-E</b>	Eco cruise control (with eco-roll and I-cruise, controls in steering wheel)
<input type="checkbox"/> <b>24AL120B</b>	120 amp alternator	<input checked="" type="checkbox"/> <b>CRUISEC</b>	Cruise control, standard
<input type="checkbox"/> <b>24AL150B</b>	150 amp alternator	<input type="checkbox"/> <b>RSENS-W</b>	Rain sensing windscreen wipers
<input checked="" type="checkbox"/> <b>CCV-C</b>	Closed crankcase engine ventilation	<input type="checkbox"/> <b>CU-ECC</b>	Electrically controlled air conditioning with sun sensor
<input type="checkbox"/> <b>CCV-OX</b>	Closed crankcase ventilation for cold markets	<input checked="" type="checkbox"/> <b>CU-MCC</b>	Climate unit with manual controlled air conditioning
<input checked="" type="checkbox"/> <b>PRIM-EL</b>	Electrical priming pump	<input checked="" type="checkbox"/> <b>IMMOBIL</b>	Thatcham H2 approved immobiliser
<input type="checkbox"/> <b>PRIM-MAN</b>	Manual priming pump	<input type="checkbox"/> <b>ALARM-B</b>	Thatcham H1 approved vehicle alarm - Cab only
<input type="checkbox"/> <b>FUEQ-EH</b>	Fuel line electric heater	<input type="checkbox"/> <b>ALARM-E</b>	Enhanced vehicle alarm - Thatcham H1 approved - Cab plus external sensor for body/trailer
<input type="checkbox"/> <b>AF-R</b>		<input type="checkbox"/> <b>ALCOLOCK</b>	Alcolock
<input type="checkbox"/> <b>FUEFE2LW</b>	Large engine mounted dual fuel filter with water separator	<input type="checkbox"/> <b>PHONE-PK</b>	Telephone preparation kit (antenna, antenna attachm. cable incl.)
<input checked="" type="checkbox"/> <b>FUEFE2SW</b>	Small engine mounted dual fuel filter with water separator	<input checked="" type="checkbox"/> <b>WLIFT-EB</b>	Electrical window lift
<input type="checkbox"/> <b>EST-AID</b>	Air inlet manifold starting heater element	<input type="checkbox"/> <b>WLIFT-ME</b>	Mechanical window lift
<input type="checkbox"/> <b>220EBH15</b>	220V/1.5Kw electric engine block heater	<input checked="" type="checkbox"/> <b>ISUNS-DS</b>	Driver's side interior sun visor
<input type="checkbox"/> <b>PTER-100</b>		<input checked="" type="checkbox"/> <b>ISUNF-B</b>	Interior front sun visor without mirror
<input type="checkbox"/> <b>PTER-DIN</b>	Rear engine mounted PTO with DIN5462 (female) splined shaft for a close coupled pump	<input type="checkbox"/> <b>ISUNF-MD</b>	Interior front sun visor with mirror on driver side
<input type="checkbox"/> <b>PTER1400</b>	Rear engine mounted power-take-off with SAE 1410 flange	<input checked="" type="checkbox"/> <b>CSPU-S</b>	One open storage (behind push open lid) in upper part of dash panel center section
<input type="checkbox"/> <b>HPE-F101</b>	Parker F1-101, engine mounted, fixed displacement, single flow, engine mounted hydraulic pump	<input checked="" type="checkbox"/> <b>BUPALARM</b>	Reverse alarm
<input type="checkbox"/> <b>HPE-F41</b>	Parker F1-41, engine mounted, fixed displacement, single flow, engine mounted hydraulic pump	<input type="checkbox"/> <b>BUPMON</b>	Back up monitor with built in 7" screen on dash and one colour camera supplied loose for fitment by bodybuilder.
<input type="checkbox"/> <b>HPE-F51</b>	Parker F1-51, engine mounted, fixed displacement, single flow, engine mounted hydraulic pump	<input type="checkbox"/> <b>RTOLL-PK</b>	Road toll PREPARATION kit for trucks operating with "Toll Collect" in Germany
<input type="checkbox"/> <b>HPE-F61</b>	Parker F1-61, engine mounted, fixed displacement, single flow, engine mounted hydraulic pump	<input type="checkbox"/> <b>LOADIND</b>	Load indicator with central dashboard display
<input type="checkbox"/> <b>HPE-F81</b>	Parker F1-81, engine mounted, fixed displacement, single flow, engine mounted hydraulic pump	<input type="checkbox"/> <b>REMC-MF</b>	Multi-function wireless remote control
<input type="checkbox"/> <b>HPE-T53</b>	Parker F2-53/53, engine mounted, Fixed displacement, Twin flow engine mounted hydraulic pump	<input type="checkbox"/> <b>FIREXT3S</b>	3kg fire extinguisher mounted on seat base
<input type="checkbox"/> <b>HPE-T70</b>	Parker F2-70/35, engine mounted, Fixed displacement, Twin flow engine mounted hydraulic pump	<input type="checkbox"/> <b>WARNVEST</b>	High visibility warning vest - no sleeves
<input type="checkbox"/> <b>HPE-V45</b>	Parker VP1-45, variable displacement, single flow, engine mounted hydraulic pump	<input type="checkbox"/> <b>AIDKIT</b>	First aid kit
<input type="checkbox"/> <b>HPE-V75</b>	Parker VP1-75, variable displacement, single flow, engine mounted hydraulic pump	<input type="checkbox"/> <b>AIDKIT1B</b>	First aid kit
<input type="checkbox"/> <b>PTPT-D</b>	Powertronic PTO, 1 front/upper DIN connection for plug-in pump (max. 850 Nm)	<input type="checkbox"/> <b>WARNLAMP</b>	Portable warning lamp
<input type="checkbox"/> <b>PTPT-F</b>	Powertronic PTO, 1 front/upper rear facing SAE flange conn. for prop shaft (max.850 Nm)	<input type="checkbox"/> <b>LAMP-IN</b>	Inspection lamp
<input type="checkbox"/> <b>PTR-D</b>	Gearbox PTO for plug-in pump, 0.71xeng speed	<input type="checkbox"/> <b>BULBKIT</b>	Bulb and fuse kit
<input type="checkbox"/> <b>PTR-DH</b>	Gearbox driven high speed PTO for one plug-in hydraulic pump	<input type="checkbox"/> <b>WRITEPAD</b>	Writing pad
<input type="checkbox"/> <b>PTR-DM</b>	Gearbox driven medium speed PTO for one plug-in hydraulic pump	<input type="checkbox"/> <b>UPHTRI10</b>	Seats: Black embossed textile insert with light grey sides, black vinyl side bolster with blue vinyl side insert. Interior trim: Raven black bunk and curtains & blue textile side
<input type="checkbox"/> <b>PTR-F</b>	Gearbox driven PTO with rear flange connection		
<input type="checkbox"/> <b>PTRD-D</b>	Gearbox driven HIGH SPEED PTO for two plug-in hydraulic pumps		
<input type="checkbox"/> <b>PTRD-F</b>	PTO with 1 DIN + 1 flange connection rear, manual gearbox		
<input type="checkbox"/> <b>HPG-F101</b>	Parker F1-101 gearbox mounted, fixed displacement, single flow, hydraulic pump		
<input type="checkbox"/> <b>HPG-F41</b>	Parker F1-41 gearbox mounted, fixed displacement, single flow, hydraulic pump		
<input type="checkbox"/> <b>HPG-F51</b>	Parker F1-51 gearbox mounted, fixed displacement, single		

Standard Equipment

Optional Equipment

For more detailed information about cab and powertrain equipment, please refer to separate specification sheets.

For all possible options and combinations of options please consult your Volvo sales contact who can create a specification to match your requirements using the Volvo Sales Support system (VSS).

The factory reserves the right to modify design and change equipment without previous notification. The specification can vary from country to country.

# MODEL RANGE

## FM 11 8x4 Platform - Rear Air Suspension - N3 Cranked front axles for on road work FM

- UPHTRI11** walls  
Seats: Light grey embossed textile insert, black raven metallic vinyl bolster with red vinyl side insert.  
Interior trim: Raven black bunk and curtains & grey vinyl side walls
- UPHTRI12** Seats: Blue soft textile insert, black vinyl bolster.  
Interior trim: Raven black bunk and curtains & blue textile side walls
- UPHTRI13** Seats: Dark grey leather insert and black leather bolster.  
Interior trim: Raven black bunk and curtains & grey vinyl side walls
- UPHTRI14** Seat: Dark grey leather insert and black leather bolster.  
Interior trim: Raven black bunk and curtains & blue textile side walls
- DST-CF4** Driver seat, comfort, suspended, belt in seat
- DST-CF5** Driver seat, comfort, suspended, belt in seat, electrically heated
- DST-CF6** Driver seat, comfort, suspended, belt in seat, electrically heated, ventilated
- SBD-RED** Red seat belts
- SBPRE-DS** Driver seat belt pretensioner
- PST-BAS1** Passenger seat - Fixed non suspended fold up with seatbelt mounted in cab
- PST-BENC** Bench passenger seat
- PST-CF2** Passenger seat - Comfort suspended & heated with seatbelt mounted in cab
- PST-CF4** Passenger seat - Comfort suspended with seatbelt mounted in seat
- PST-CF5** Passenger seat - Comfort suspended & heated with seatbelt mounted in seat
- PST-STD2** Passenger seat - Fixed non suspended with seatbelt mounted in cab
- PST-STD4** Passenger seat - Standard suspended with seatbelt mounted in cab
- SBPRE-PS** Passenger seat belt pretensioner
- ARM-DBPS** Two armrests on driver seat and one (outer) on passenger seat
- ARMRE-BB** Two armrests on both driver and passenger seat.
- ARMRE-DB** Two armrests, on driver seat only
- ARMRE-PB** Two armrests, on passenger seat only
- ARMRE-PS** Single armrest (next to driver) on passenger seat
- ARU-BAS** Vinyl upholstered armrest
- ARU-LEA** Leather upholstered armrest
- FMAT-RUB** Rubber floor mats
- FMAT-TX2** Textile and rubber floor mats
- LBK-RES** Foldable rest bunk
- LBK70** Lower bunk 700 x2000 mm, fixed
- ULBK** Without lower bunk
- MATL-FI** Firm lower bunk pocket sprung mattress
- MATL-SF** Lower flexizone mattress - semi-firm, pocket springs up to 100kg - 16 stone
- MATL-SO** Lower flexizone mattress - soft, pocket springs up to 85kg - 13.5 stone
- OLMAT-BA** 35mm mattress overlay protector
- OLMAT-PR** 50mm premium mattress overlay protector
- TBK60F** Fixed foldable top bunk 600 x 1900mm
- TBK70F** Fixed foldable top bunk 700 x 1900mm
- PH-CAB2** 1.8kW Air to air night heater
- PH-ENGCA** Engine and cab night heater
- PH-SS** Short stop heater
- SLCP-BAS** Basic sleeper control panel - includes interior light, parking heater, roof hatch and door lock
- SAFE** Safe box for driver's personal items
- ETSB-F** Storage on engine tunnel - on front top
- ETSB-FR** Storage on engine tunnel - on front top and at rear cab wall
- ETSB-FRS** Storage on engine tunnel - on front top & at rear cab wall &
- ETSB-FS** storage recessed into tunnel on right hand side  
Storage on engine tunnel - on front top and storage recessed into tunnel on right hand side
- ETSB-R** Storage on engine tunnel - box at rear cab wall
- ETSB-RS** Storage on engine tunnel - at rear cab wall and storage recessed into tunnel on right hand side
- ETSB-S** Storage on engine tunnel - recessed into tunnel on right hand side
- RUS-BAS** Rear cab upper storage 154 litres - 300 mm high
- TABLE** Folding and height adjustable table - on lower bunk
- REF-ICPK**
- REFR-RUS** 28 litre rear upper wall mounted refrigerator with dividers
- BOTH-D** One bottle holder under dashboard centre section
- COFMA-PK** Coffee maker, preparation kit.
- INLI-BAS** Basic white interior lights
- INLI-NL** Interior white and red night light with no dimmer
- INLI-NLD** Interior white and red night light with dimmer function
- ARL-FLEX** Two flexible reading lamps (snake lamps)
- RH-ECS** Glass roof hatch - Electrically operated
- RH-MSR** Steel roof hatch - Manually operated with rear opening
- URH** Without roof hatch
- SWIND-PS** Rear side window, passenger side

### CAB EXTERIOR

- PAICS-B** Basic cab paint - mirrors, sunvisor, instep and bumper supplied in natural finish - grey
- PAICS-C** Complete cab - mirrors, insteps, sunvisor, and bumper finished in cab colour
- GLAS-TIN** Tinted windows.
- AWIND-RF** Rear window
- LOCK-MAN** Manual door locking
- LOCK-MRP** Manual door locking with internal remote control (from driver side) of passenger door
- LOCK-REM** Central locking with remote control
- BUMP-B** Plastic front bumper
- BUMP-B2** Steel front bumper
- BUMP-SP** Front bumper spoiler
- GUARD-EH** Guard plate for cooling pipes and oil sump
- BUGNET** Insect screen in front of radiator
- CTILT-P-E** Electrically operated hydraulic cab tilt
- CTILT-P-M** Manually operated hydraulic cab tilt
- FCABS-A** Front cab - Air suspension
- FCABS-M** Front cab - Mechanical spring suspension
- RCABS-A** Rear cab suspension - Air
- RCABS-M** Rear cab suspension - Mechanical spring
- MIRCOMF** Electrically heated and operated main mirror and wide angle mirrors on both sides, manual kerb view mirror on passenger side
- MIRCOMF2** Basic electrically heated and operated mirrors FMX style with wide angle and passenger kerb mirror, to increase vision side mirrors have no mirror cowlings.
- MIRCOMFM** Electrically heated and operated main mirror with heated wide angle mirror on both sides, manual kerb view mirror on passenger side
- MIRSTD2** Basic electrically heated FMX style main with wide angle and passenger kerb mirror, to increase vision side mirrors have no mirror cowlings.
- MIRSTDFM** Electrically heated exterior mirrors with wide angle mirror on both sides and kerb view mirror on passenger side
- AMIR-F20** Auxiliary front view mirror with a 200mm radius
- SUNV-H** External smoke grey sunvisor
- AD-ROOF** Roof air deflector

Standard Equipment

Optional Equipment

For more detailed information about cab and powertrain equipment, please refer to separate specification sheets.

For all possible options and combinations of options please consult your Volvo sales contact who can create a specification to match your requirements using the Volvo Sales Support system (VSS).

The factory reserves the right to modify design and change equipment without previous notification. The specification can vary from country to country.

# MODEL RANGE

## FM 11 8x4 Platform - Rear Air Suspension - N3 Cranked front axles for on road work FM

- **AD-ROOFB** Roof air deflector with light box
- **AD-SIDEL** Side air deflector extension panels
- **AD-SIDES** Short cab side air deflector for rigid bodywork
- **HL-BASIC** Halogen H7 head lamps
- **HL-BHID** High intensity Bi-Xenon head lamps
- **HL-DBL** Bi-Xenon high intensity discharge and dynamic head lamps. Dipped beam follows the road, activated by a signal from the steering system.
- **HL-CLEAN** Head lamp cleaner - washer jets
- **HLP-ST** Steel headlamp protection
- **HL-ADJ** Adjustable headlights with switch in the cab
- **DRIVL2** Two spot lamps
- **UDRIVL** Without auxiliary driving lights
- **FOGL-WC** Front fog lights
- **CL-STAT** Static corner lights
- **ASL-RF2** Two Hella H11 70W spotlamps in sign box - only available with the basic headlight and no lower driving lights.
- **ASL-RFPK** Preparation kit for two spotlamps in sign box
- **BEACOA2F** Two front roof mounted amber beacon rotating warning lamps
- **BEACOA2R** Two rear roof mounted (on accessory bracket) amber beacon flashing warning LED lamps
- **BEACON-P** Roof beacon wire preparation
- **CABPT-R1** Single outlet for roof mounted accessories
- **CABPT-R2** Twin outlets for roof mounted accessories.
- **SPOTP-F** Spotlamp preparation in front, max 280W
- **SPOTP-R** Spotlamp preparation on roof, max 280W
- **SPOTP-RF** Spotlamp preparation on cab roof and in cab front, max 2x280W
- **ROS-IL** Globetrotter roof sign illuminated
- **CSGN-GTR** Globetrotter headboard logo
- **HORN-F1S** Single tone Jericho air horn chassis mounted
- **HORN-R2S** Two roof mounted air horns
- **ANT-CBR** Roof mounted antenna for CB radio, single aerial
- **ACCB-R-F** Front roof mounted accessory bracket
- **ACCB-R-R** Rear roof mounted accessory bracket
- **REFS-TW** White cab conspicuity markings by packed in cab
- **REFS-TY** Yellow cab conspicuity markings by packed in cab
- **WLC-PKLH** Preparation kit - cables and switch for low and high mounted working lamps back of cab.
- **ECBB-BAS** Body builder electrical centre without body builder module
- **ECBB-HIG** Body builder electrical centre with body builder module
- **BBCHAS1** One 7-pole connector for Body builder interface
- **BBCHAS3** Three 7-pole connectors for Body builder interface
- **BEPR-T2** Body builder electrical software preparation for tipper with remote control
- **TD-BAS** Trailer detection WITHOUT LED sensing
- **TD-LED** Trailer detection with LED sensing
- **FRFS-BS** Frame rail free space on both sides to give space for crane legs or other equipment.
- **FBA-BTF** Lower front body attachments for torsionally flexible - platform body
- **FBA-BTSF** Lower front body attachments for torsionally semi-flexible body - box or curtainsider
- **HBA-FSFB** Holes for body attachments - flexible/semi-flexible body
- **HBA-SB** Holes for body attachments - stiff body
- **RBA-T2** Lower rear body attachments for helper frame
- **CRANEPK1** Crane plates mounted to frame, for cranes up to 10 tonne metre capacity
- **CRANEPK2** Crane plates mounted to frame, for cranes up to 20 tonne metre capacity
- **CRANEPK4** Crane plates mounted to frame, for cranes up to 40 tonne metre capacity
- **AUXL-SPK** Electrical preparation kit - wiring and switch for snow plough lights
- **TAILPRE2** Tail lift preparation kit, wireless remote operation
- **TAILPREP** Taillift preparation kit - cab switch and warning in driver display
- **AESW2** Two Body builder bistable electrical switches (marked AUX1 / AUX2)
- **AESW2PK** 2 Body builder bistable el.switches (marked AUX1/AUX2) and prep. for 4 more switches
- **AUXSW-4** Wiring for 4 extra switches (from Body builder electrical centre to switch positions)

### SUPERSTRUCTURE PREPARATIONS

- **BP-MI02**
- **BP-TI03**
- **SRWL-2RW** Two H3 70W white rear chassis mtd (LH/RH side) working lamps & 3-pos switch(On/Off/Reverse auto on)
- **SRWL-PK** Wiring preparation for side & rear work/reverse lamps on side of chassis and a three-position switch, maximum 280W
- **SWL-2FW** Two H3 70W white front chassis mounted (LH/RH side) working lamps and a 2-position switch (On/Off)
- **SWL-2RW** Two H3 70W white rear chassis mounted (LH/RH side) working lamps and a 2-position switch (On/Off)
- **SWL-4W** 4 H3 70W white front (2) & rear (2) chassis mtd (LH/RH side) working lamps & 2-pos switch (On/Off)
- **SWL-PK** Wiring preparation for side work/reverse lamps on side of chassis and a three-position switch, maximum 280W
- **WLC-H2A** Two H3/70W working lamps with amber coloured lens high mounted back of cab
- **WLC-H2W** Two H3/70W white working lamps high mounted on the back of cab
- **WLC-PKCH** Preparation kit (cables and switch) for cab mounted chassis working lamp
- **WLC-PKH** Preparation kit, cables and switch for high mounted working lamps back of cab
- **WLC-PKL** Preparation kit, cables and switch for low mounted working lamps back of cab

### DELIVERY SERVICES

- **TGW-3GWL** Telematics gateway with GSM/GPRS/3G modem and wireless lan WLAN
- **TESP-T** Driver Service Platform with Dynafleet Telematics
- **TESP-TN** Driver Service Platform with Dynafleet Telematics and Navigation
- **FMS-PK** Fleet Management System gateway



Volvo Truck Corporation  
www.volvotrucks.com